

Features

- **N-Channel MOSFET**
- **BV_{DSS} (Minimum) : 650 V**
- **$R_{DS(ON)}$ (Maximum) : 2.2 ohm**
- **I_D : 4.0 A**
- **Q_g (Typical) : 16nc**
- **P_D (@TC=25 °C) : 106W**

General Description

This power MOSFET is produced with advanced VDMOS technology of SAMWIN. This technology enable power MOSFET to have better characteristics, such as fast switching time, low on resistance, low gate charge and especially excellent avalanche characteristics. This power MOSFET is usually used at high efficient DC to DC converter block and switch mode power supply.



**TO-220
SW P 4N65**

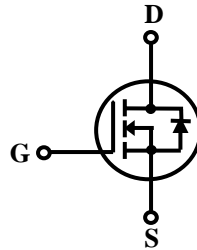

Absolute Maximum Ratings

Symbol	Parameter	Value	Units
V_{DSS}	Drain to Source Voltage	650	V
I_D	Continuous Drain Current (@Tc=25°C)	4.0	A
	Continuous Drain Current (@Tc=100°C)	2.8	A
I_{DM}	Drain Current Pulsed (Note 1)	16	A
V_{GS}	Gate to Source Voltage	±30	V
E_{AS}	Single Pulsed Avalanche Energy (Note 2)	250	mJ
E_{AR}	Repetitive Avalanche Energy (Note 1)	10.6	mJ
dv/dt	Peak Diode Recovery dv/dt (Note 3)	4.5	V/ns
P_D	Total Power Dissipation (@Tc=25°C)	106	W
	Derating Factor above 25°C	0.85	W/°C
T_{STG}, T_J	Operating junction temperature & Storage temperature	-55~+150	°C
T_L	Maximum Lead Temperature for soldering purpose, 1/8 from Case for 5 seconds.	300	°C

Thermal Characteristics

Symbol	Parameter	Value			Units
		Min	Typ	Max	
$R_{\theta JC}$	Thermal Resistance, Junction-to-Case	-	-	1.18	°C/W
$R_{\theta CS}$	Thermal Resistance, Case-to-Sink	-	0.5		°C/W
$R_{\theta JA}$	Thermal Resistance, Junction-to-Ambient	-	62.5		°C/W

Electrical Characteristics (Tc=25°C unless otherwise noted)

Symbol	Parameter	Test Conditions	Value			Units
			Min	Typ	Max	
Off Characteristics						
BV _{DSS}	Drain- Source Breakdown Voltage	V _{GS} =0V, I _D =250uA	650	-	-	V
ΔBV _{DSS} /ΔT _J	Breakdown Voltage Temperature coefficient	I _D =250uA, referenced to 25°C	-	0.5	-	V/°C
I _{DSS}	Drain-Source Leakage Current	V _{DS} =600V, V _{GS} =0V	-	-	1	uA
		V _{DS} =480V, Tc=125°C				
I _{GSS}	Gate-Source Leakage Current	V _{GS} =30V, V _{DS} =0V	-	-	100	nA
	Gate-Source Leakage Reverse	V _{GS} =-30V, V _{DS} =0V	-	-	-100	nA
On Characteristics						
V _{GS(th)}	Gate Threshold Voltage	V _{DS} =V _{GS} , I _D =250uA	2.0	-	4.0	V
R _{DS(ON)}	Static Drain-Source On-state Resistance	V _{GS} =10V, I _D =2A	-	2.03	2.2	ohm
Dynamic Characteristics						
C _{iss}	Input Capacitance	V _{GS} =0V, V _{DS} =25V, f=1MHz	-	600	700	pF
C _{oss}	Output Capacitance		-	75	95	
C _{rss}	Reverse Transfer Capacitance		-	9	12	
Dynamic Characteristics						
t _{d(on)}	Turn-on Delay Time	V _{DD} =300V, I _D =4.0A (Note4,5)	-	20	40	ns
t _r	Rise Time		-	28	100	
t _{d(off)}	Turn-off Delay Time		-	45	160	
t _f	Fall Time		-	48	165	
Q _g	Total Gate Charge	V _{DS} =480V, V _{GS} =10V, I _D =4.0A (Note4,5)	-	16.5	22	nC
Q _{gs}	Gate-Source Charge		-	3.8	-	
Q _{gd}	Gate-Drain Charge (Miller Charge)		-	7.5	-	

Source-Drain Diode Ratings and Characteristics

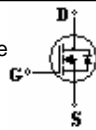
Symbol	Parameter	Test Conditions	Min.	Typ.	Max.	Unit.
I _S	Continuous Source Current	Integral Reverse p-n Junction Diode in the MOSFET 	-	-	4.0	A
I _{SM}	Pulsed Source Current		-	-	16.0	
V _{SD}	Diode Forward Voltage	I _S =1.0A, V _{GS} =0V	-	-	1.4	V
t _{rr}	Reverse Recovery Time	I _S =1.0A, V _{GS} =0V, di _r /dt=100A/us	-	250	-	ns
Q _{rr}	Reverse Recovery Charge		-	1.5	-	uc

※NOTES

1. Repeativity rating: pulse width limited by junction temperature
2. L=25mH, I_{AS}=4.0A, V_{DD}=50V, R_G=0ohm, Starting T_J=25°C
3. I_{SD}≤4.0A, di/dt≤100A/us, V_{DD}≤BV_{DSS}, Starting T_J=25°C
4. Pulse Test: Pulse Width≤300us, Duty Cycle≤2%
5. Essentially independent of operating temperature.

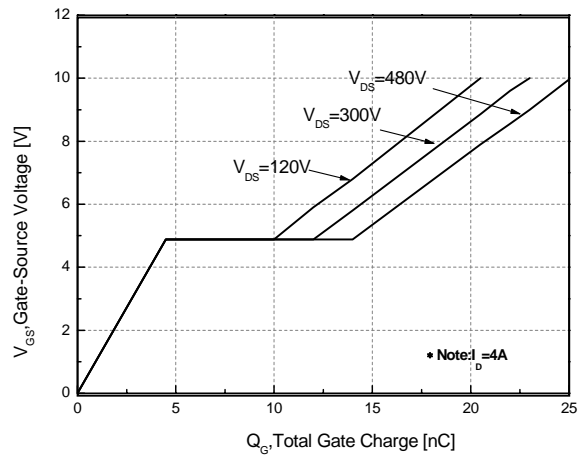
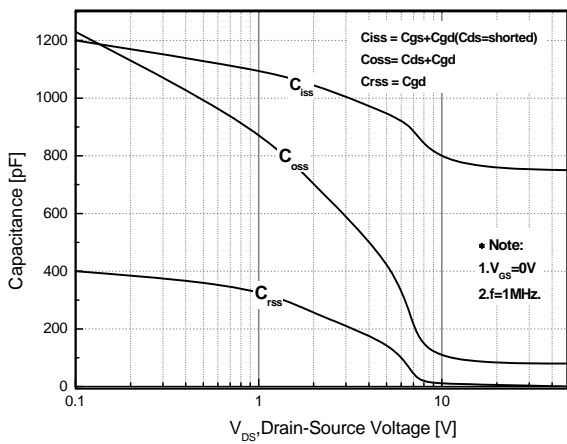
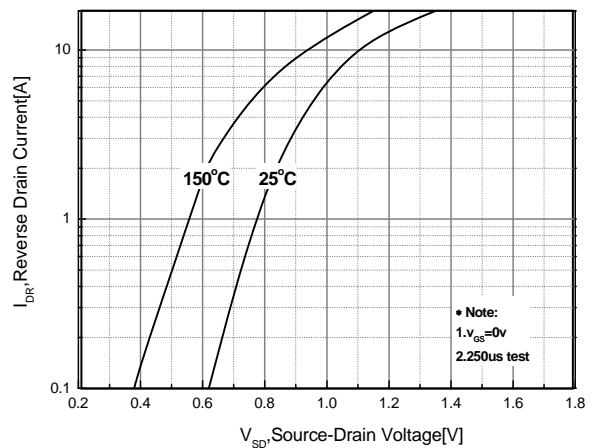
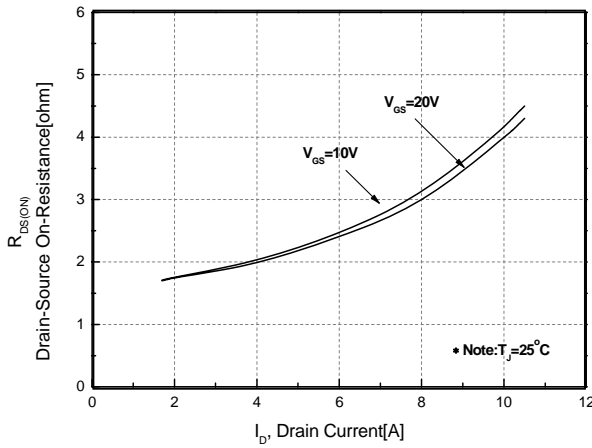
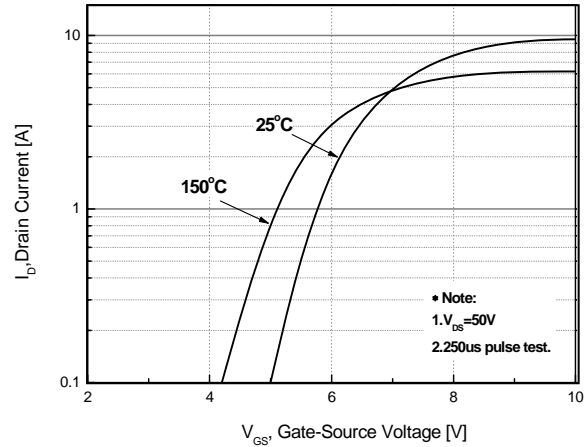
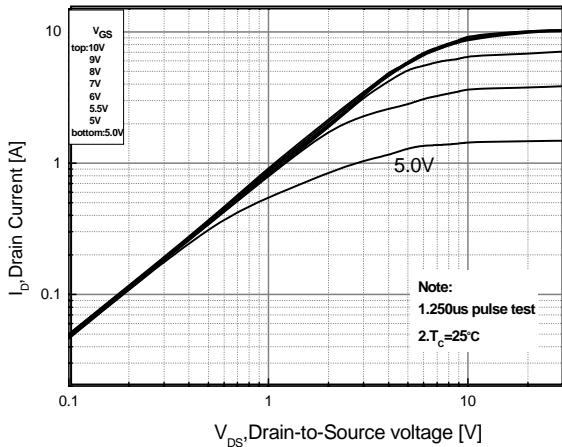

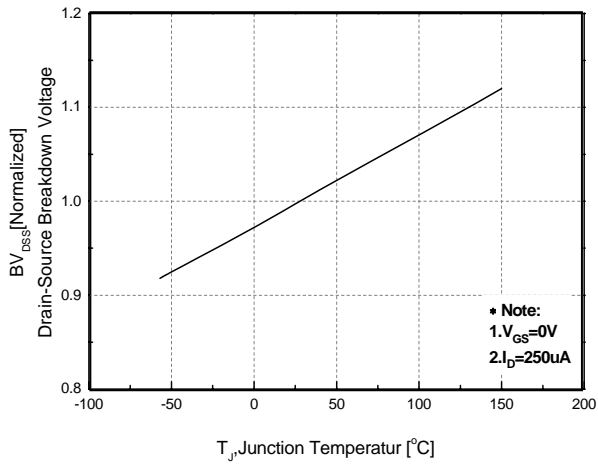

Fig 7. Breakdown Voltage Variation vs. Junction Temperature

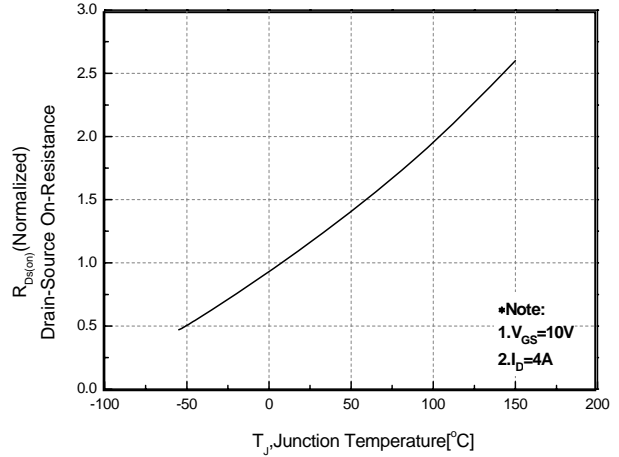

Fig 8. On-Resistance Variation vs. Junction Temperature

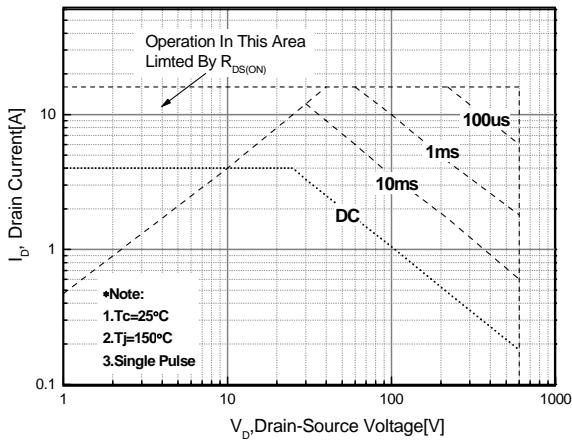

Fig 9. Maximum Safe Operating

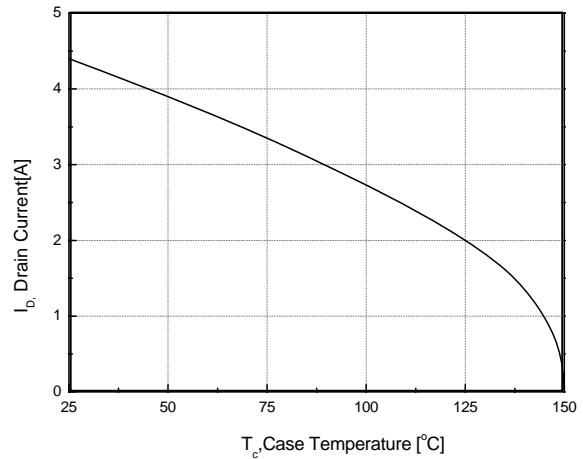

Fig 10. Maximum Drain Current Vs. Case Temperature

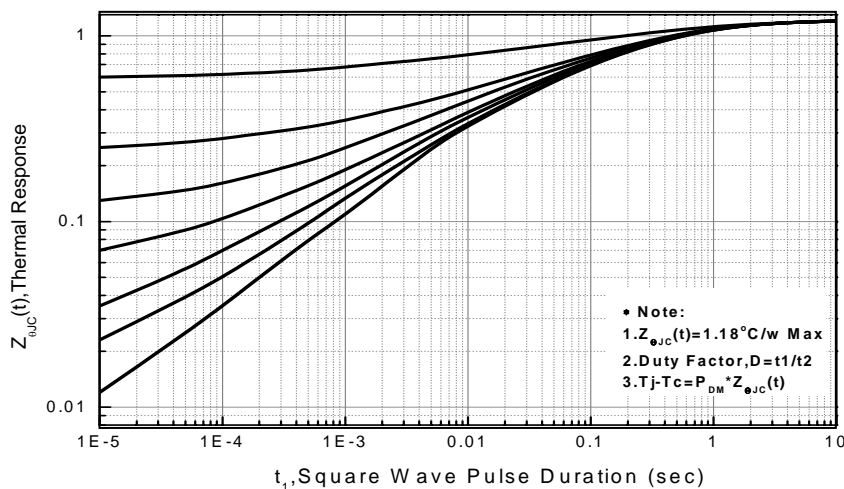

Fig 11. Transient Thermal Response Curve

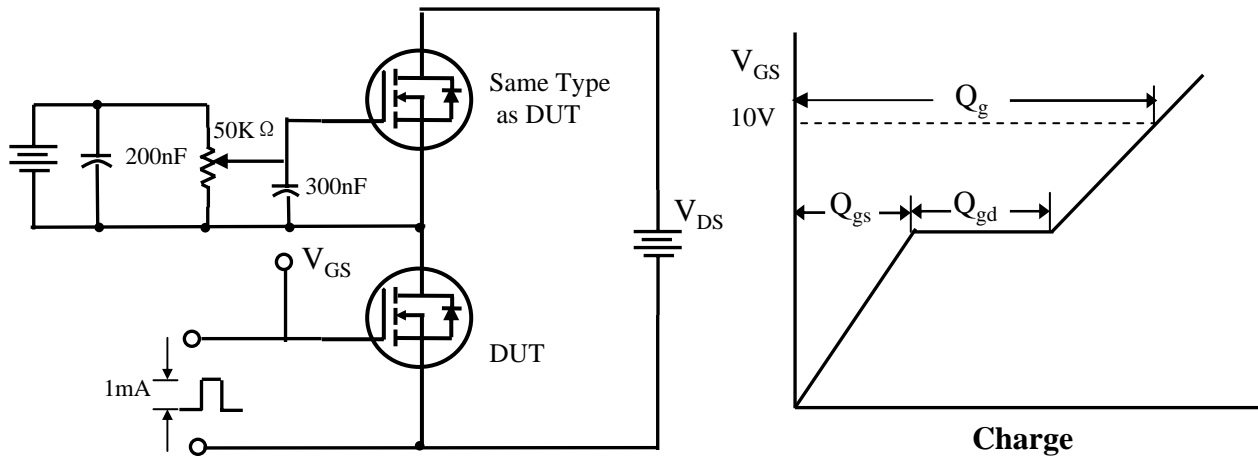

Fig 12. Gate Charge test Circuit & Waveforms

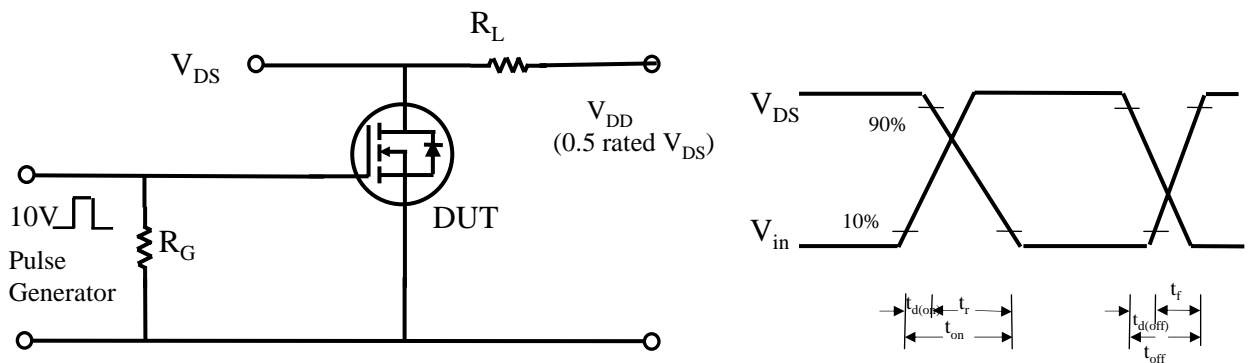

Fig 13. Switching test Circuit & Waveforms

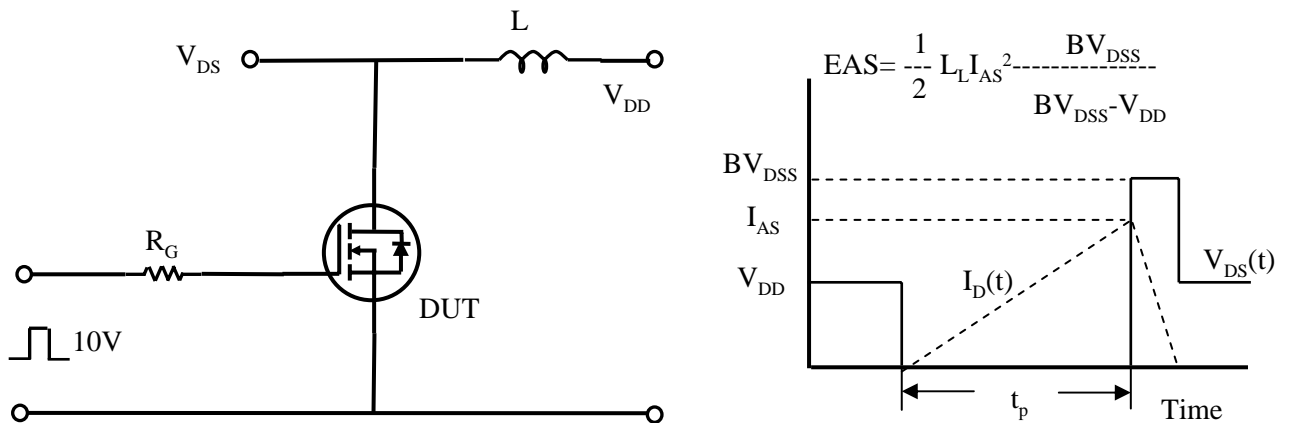

Fig 14. Unclamped Inductive Switching test Circuit & Waveforms

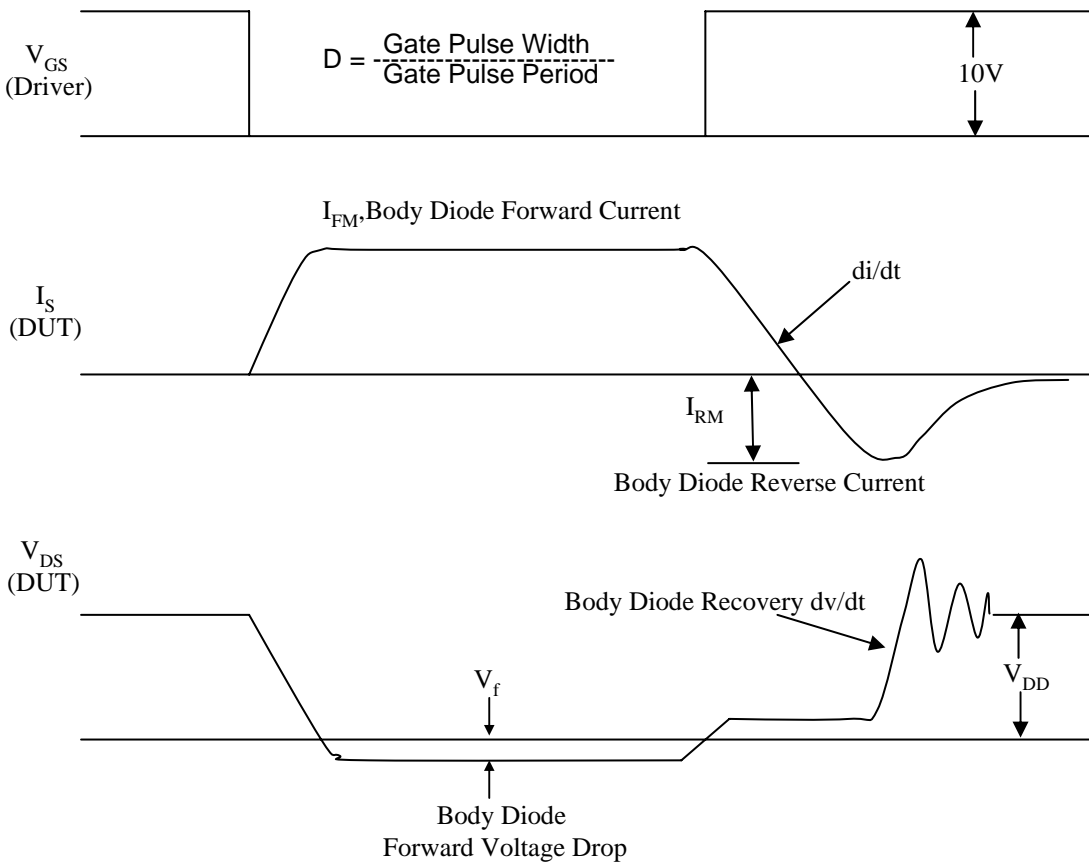
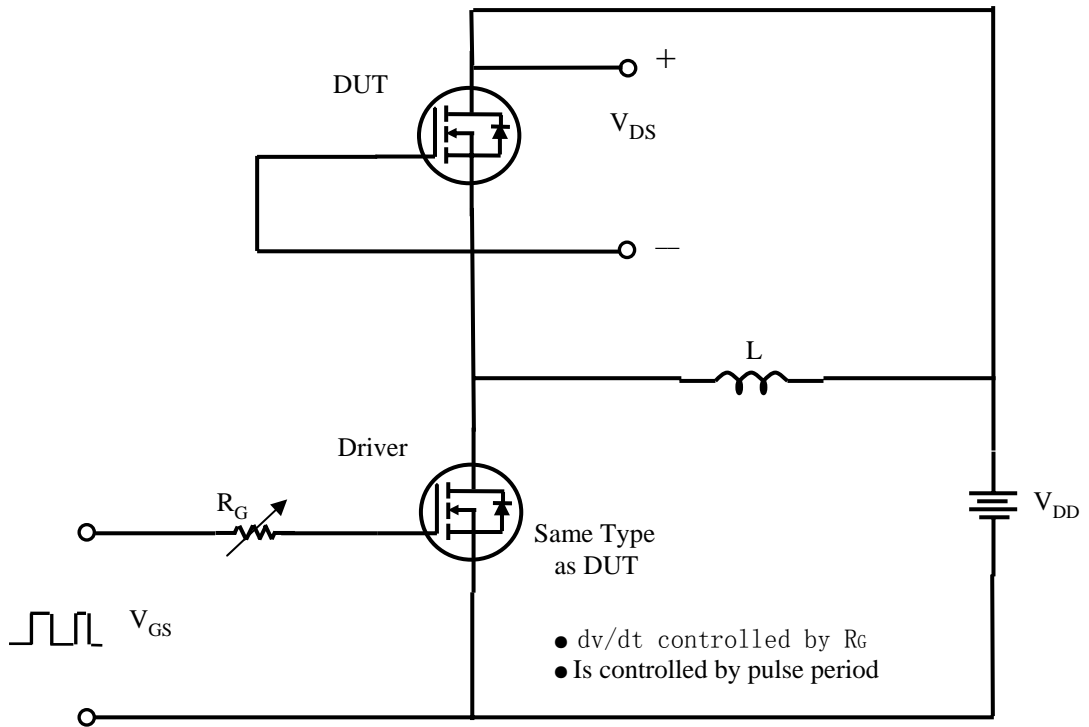
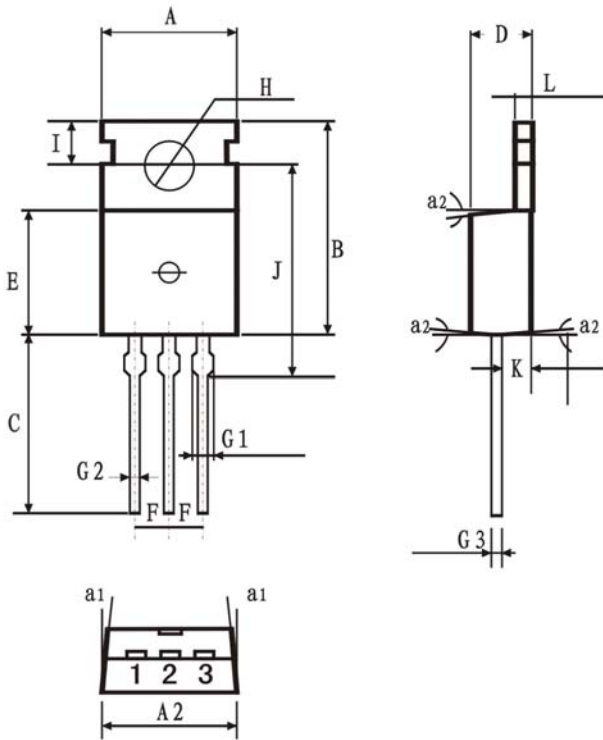

Fig 15. Peak Diode Recovery dv/dt test Circuit & Waveforms

Package Dimensions TO-220



A(mm)	9.66~10.28
A2(mm)	9.80~10.20
B(mm)	15.6~15.8
C(mm)	12.70~14.27
D(mm)	4.30~4.70
E(mm)	8.59~9.40
F(mm)	typical 2.54
G1(mm)	1.32~1.72
G2(mm)	0.70~0.95
G3(mm)	0.4~0.60
H(mm) dia.	3.50~3.83
I(mm)	2.7~2.9
J(mm)	15.70~16.25
K(mm)	2.20~2.90
L(mm)	1.15~1.40
a(degree)	45°
a2(degree)	3° ±0.5°
a3(degree)	3° ±0

HISTORY

Issue No	Changed Characteristics	Date	Issuer
V 1.01	Origination	2007.06.05	