

Features

- **N-Channel MOSFET**
- **BV_{DSS} (Minimum) : 200 V**
- **$R_{DS(ON)}$ (Maximum) : 0.18 ohm**
- **I_D : 18A**
- **Q_g (Typical) : 40 nc**
- **P_D (@TC=25) : 139 W**

General Description

This power MOSFET is produced with advanced VDMOS technology of SAMWIN. This technology enable power MOSFET to have better characteristics, such as fast switching time, low on resistance, low gate charge and especially excellent avalanche characteristics. It is mainly suitable for half bridge or full bridge resonant topology like a electronic ballast, and also low power switching mode power appliances.



**TO-220
SW P 640**

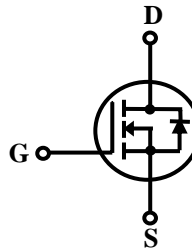

Absolute Maximum Ratings

Symbol	Parameter	Value	Units
V_{DSS}	Drain to Source Voltage	200	V
I_D	Continuous Drain Current (@Tc=25)	18	A
	Continuous Drain Current (@Tc=100)	11.4	A
I_{DM}	Drain Current Pulsed (Note 1)	72	A
V_{GS}	Gate to Source Voltage	± 30	V
E_{AS}	Single Pulsed Avalanche Energy (Note 2)	250	mJ
E_{AR}	Repetitive Avalanche Energy (Note 1)	13.9	mJ
dv/dt	Peak Diode Recovery dv/dt (Note 3)	5.5	V/ns
P_D	Total Power Dissipation (@Tc=25)	139	W
	Derating Factor above 25	1.10	W/
T_{STG}, T_J	Operating junction temperature & Storage temperature	-55~+150	
T_L	Maximum Lead Temperature for soldering purpose, 1/8 from Case for 5 seconds.	300	

Thermal Characteristics

Symbol	Parameter	Value			Units
		Min	Typ	Max	
R_{JC}	Thermal Resistance, Junction-to-Case	-	-	0.9	/ W
R_{CS}	Thermal Resistance, Case-to-Sink	-	-	0.5	/ W
R_{JA}	Thermal Resistance, Junction-to-Ambient	-	-	62.5	/ W

Electrical Characteristics (Tc=25 unless otherwise noted)

Symbol	Parameter	Test Conditions	Value			Units
			Min	Typ	Max	
Off Characteristics						
BV _{DSS}	Drain- Source Breakdown Voltage	V _{GS} =0V, I _D =250uA	200	-	-	V
BV _{DSS} /T _J	Breakdown Voltage Temperature coefficient	I _D =250uA, referenced to 25	-	0.2	-	V/
I _{DSS}	Drain-Source Leakage Current	V _{DS} =200V, V _{GS} =0V	-	-	1	uA
		V _{DS} =160V, Tc=125				
I _{GSS}	Gate-Source Leakage Current	V _{GS} =30V, V _{DS} =0V	-	-	100	nA
	Gate-Source Leakage Reverse	V _{GS} =-30V, V _{DS} =0V	-	-	-100	nA
On Characteristics						
V _{GS(th)}	Gate Threshold Voltage	V _{DS} =V _{GS} , I _D =250uA	2.0	-	4.0	V
R _{DS(ON)}	Static Drain-Source On-state Resistance	V _{GS} =10V, I _D =3.25A	-	0.15	0.18	ohm
Dynamic Characteristics						
Ciss	Input Capacitance	V _{GS} =0V, V _{DS} =25V, f=1MHz	-	1350	1750	pF
Coss	Output Capacitance		-	180	240	
Crss	Reverse Transfer Capacitance		-	45	60	
Dynamic Characteristics						
t _{d(on)}	Turn-on Delay Time	V _{DD} =200V, I _D =6.5A R _G =50ohm (Note4,5)	-	25	50	ns
t _r	Rise Time		-	80	230	
t _{d(off)}	Turn-off Delay Time		-	150	300	
t _f	Fall Time		-	70	200	
Q _g	Total Gate Charge	V _{DS} =320V, V _{GS} =10V, I _D =6.5A (Note4,5)	-	40	55	nC
Q _{gs}	Gate-Source Charge		-	6	-	
Q _{gd}	Gate-Drain Charge (Miller Charge)		-	21	-	

Source-Drain Diode Ratings and Characteristics

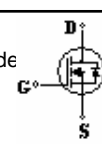
Symbol	Parameter	Test Conditions	Min.	Typ.	Max.	Unit.
I _S	Continuous Source Current	Integral Reverse p-n Junction Diode in the MOSFET 	-	-	18	A
I _{SM}	Pulsed Source Current		-	-	72	
V _{SD}	Diode Forward Voltage	I _S =6.5A, V _{GS} =0V	-	-	1.5	V
t _{rr}	Reverse Recovery Time	I _S =6.5A, V _{GS} =0V, di _f /dt=100A/us	-	195	-	ns
Q _{rr}	Reverse Recovery Charge		-	1.47	-	uc

NOTES

1. Repeativity rating: pulse width limited by junction temperature
2. L=18.6mH, I_{AS}=18A, V_{DD}=50V, R_G=0ohm, Starting T_J=25
3. I_{SD} 18A, di/dt 100A/us, V_{DD} BV_{DSS}, Starting T_J=25
4. Pulse Test: Pulse Width 300us, Duty Cycle 2%
5. Essentially independent of operating temperature.

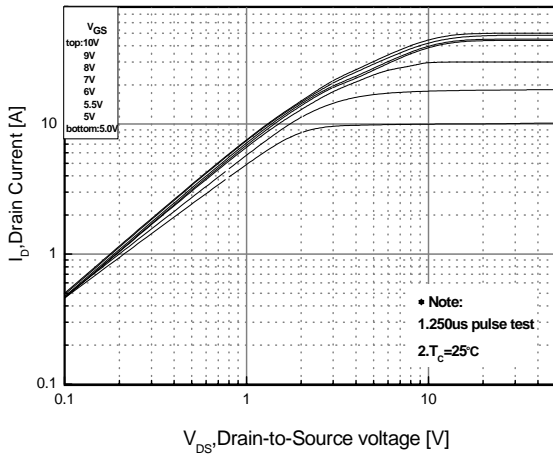

Fig 1. On-State Characteristics

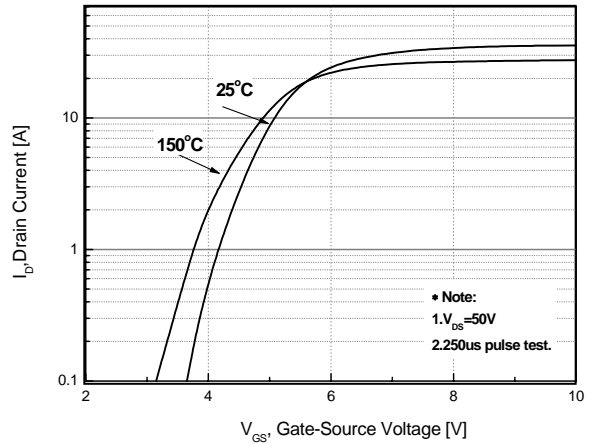

Fig 2. Transfer Characteristics

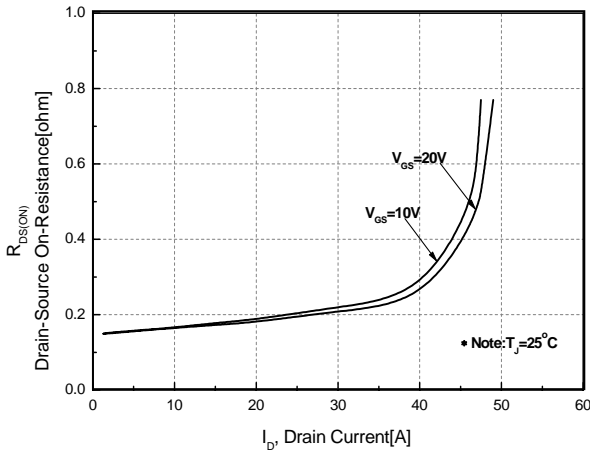

Fig 3. On Resistance Variation vs. Drain Current and Gate Voltage

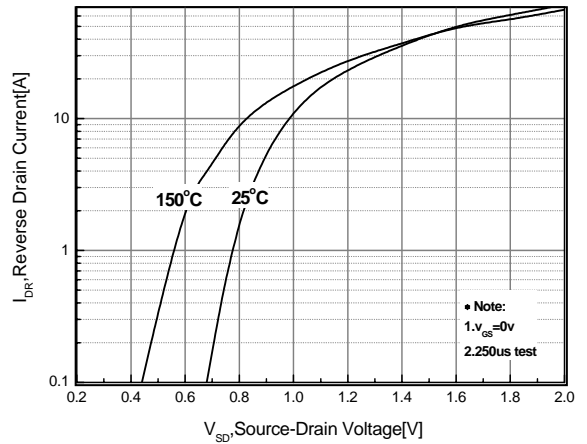

Fig 4. On State Current vs. Allowable Case Temperature

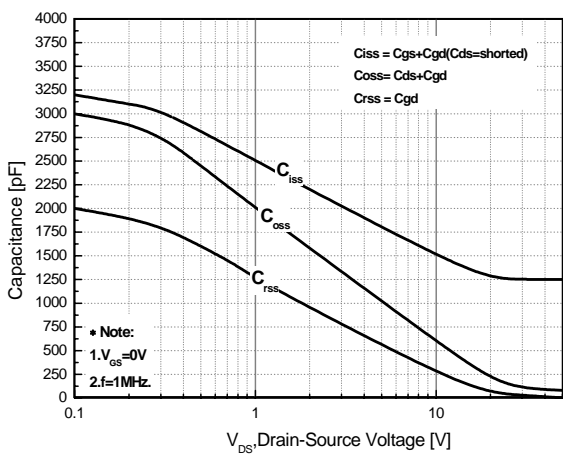

Fig 5. Capacitance Characteristics (Non-Repetitive)

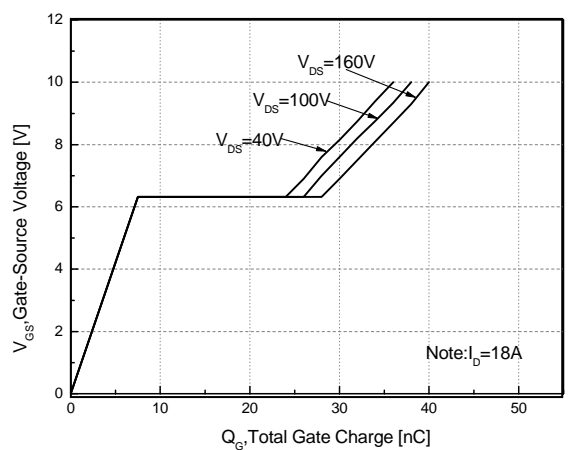

Fig 6. Gate Charge Characteristics

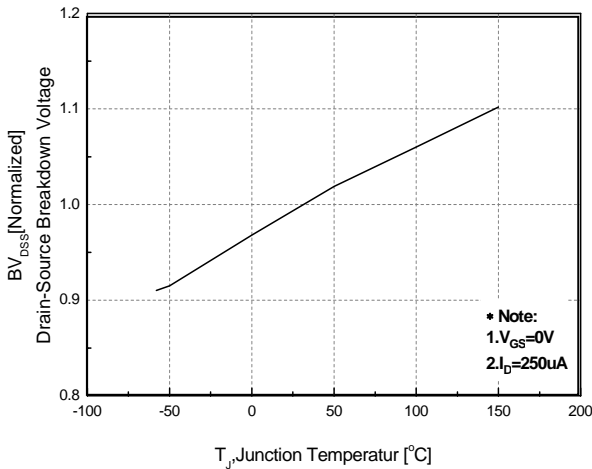

Fig 7. Breakdown Voltage Variation vs. Junction Temperature

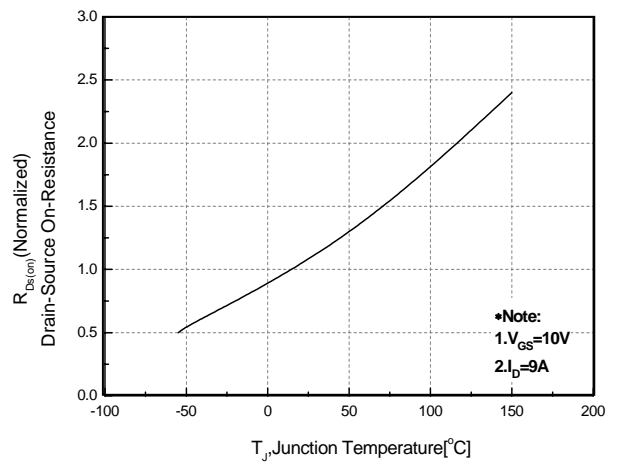

Fig 8. On-Resistance Variation vs. Junction Temperature

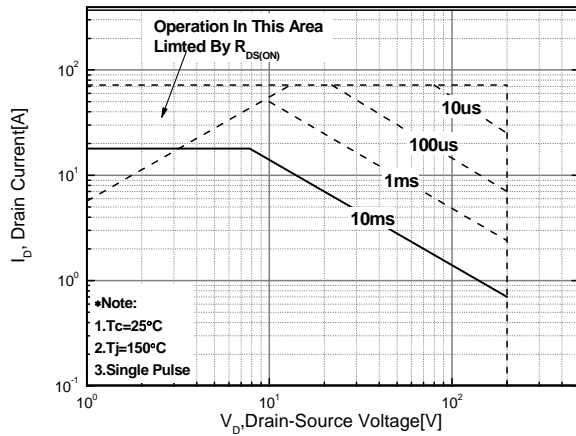

Fig 9. Maximum Safe Operating

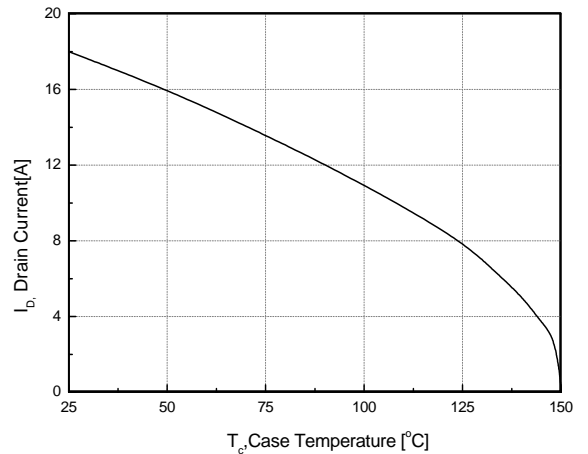

Fig 10. Maximum Drain Current Vs. Case Temperature

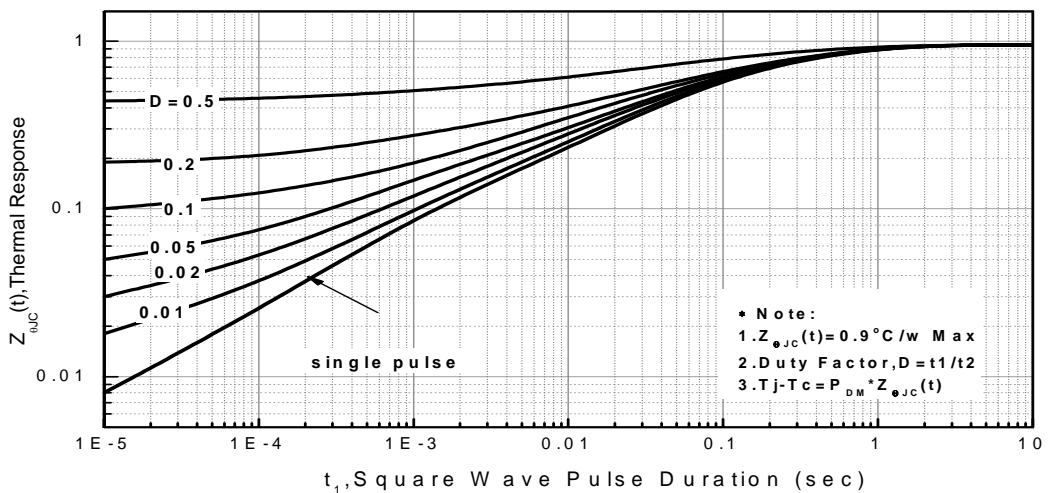

Fig 11. Transient Thermal Response Curve

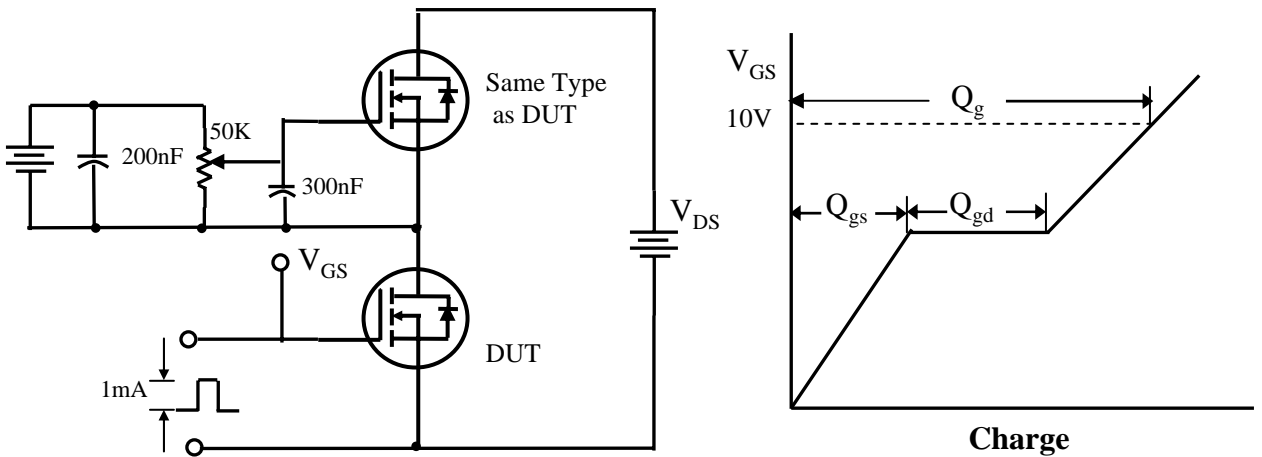

Fig 12. Gate Charge test Circuit & Waveforms

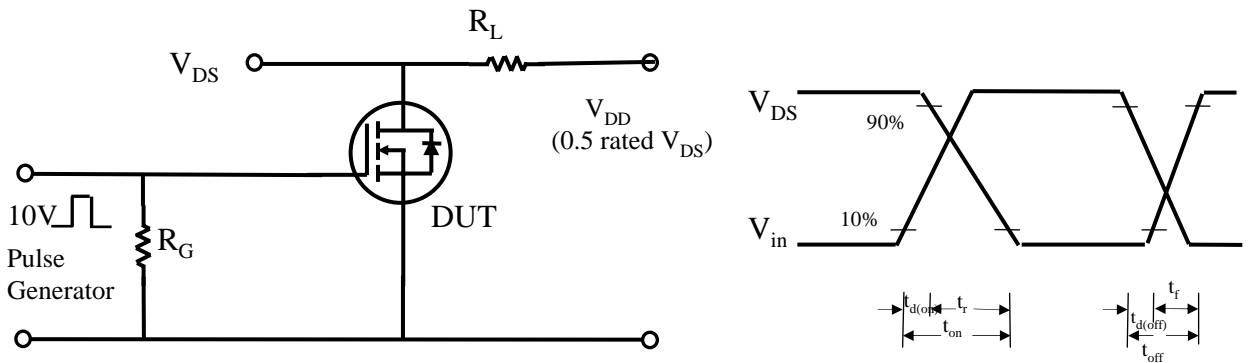

Fig 13. Switching test Circuit & Waveforms

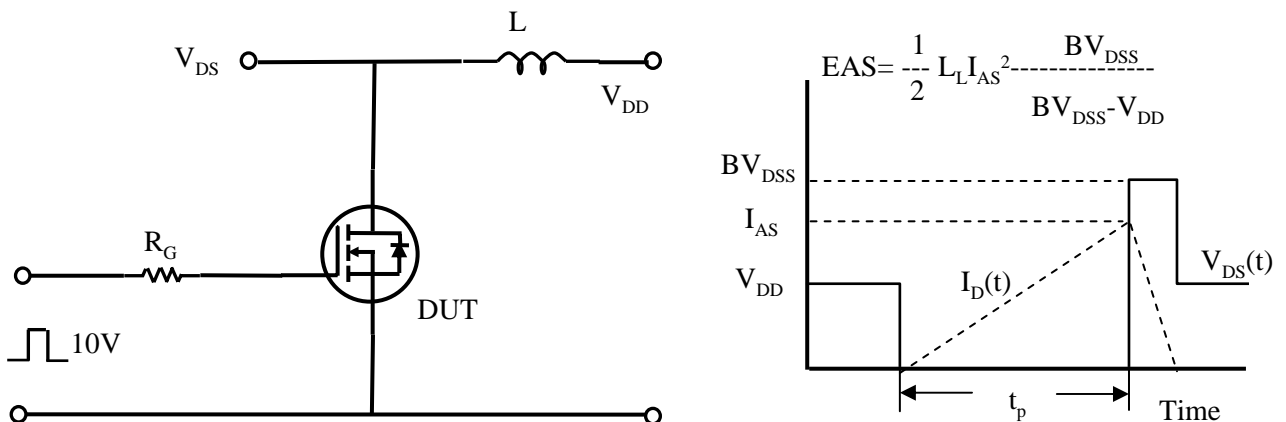

Fig 14. Unclamped Inductive Switching test Circuit & Waveforms

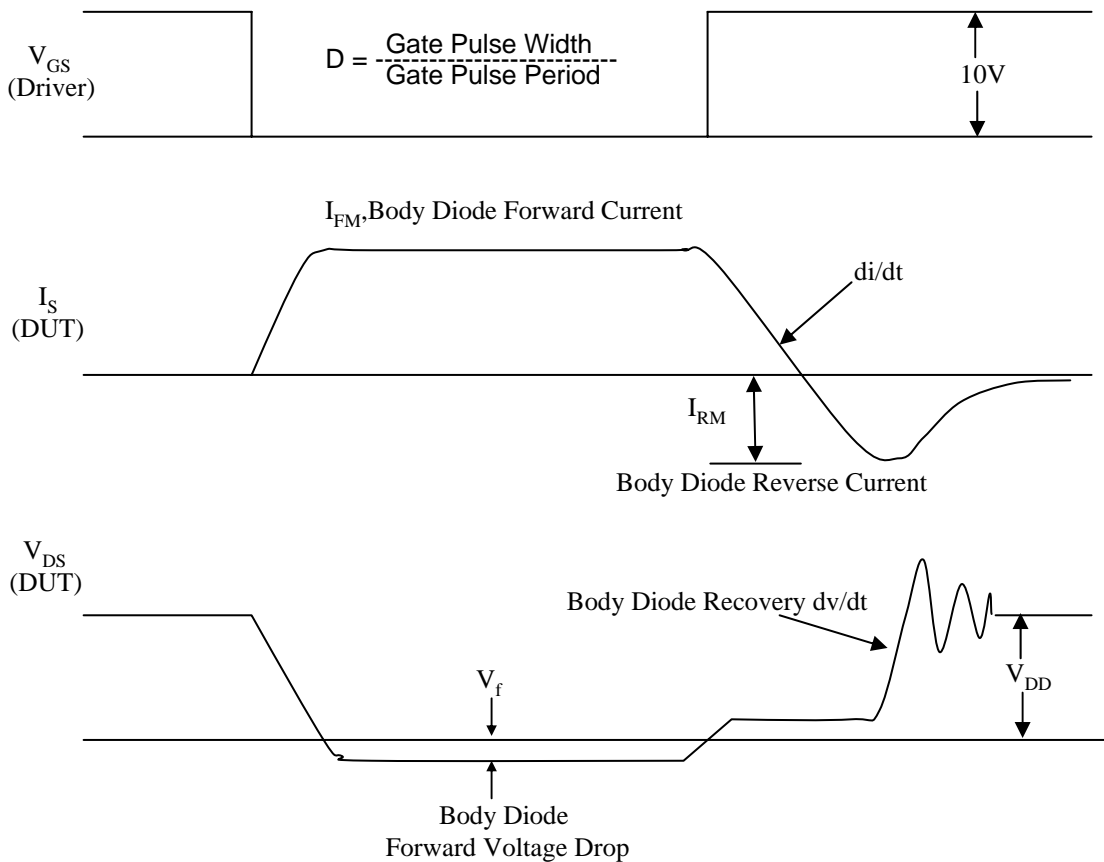
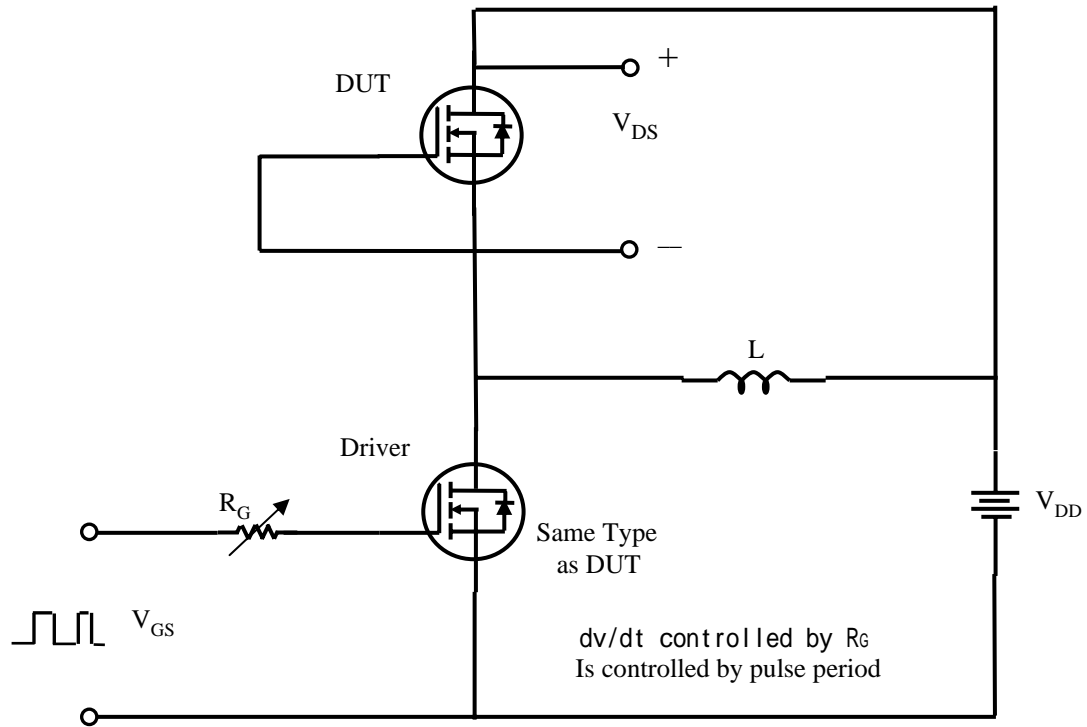
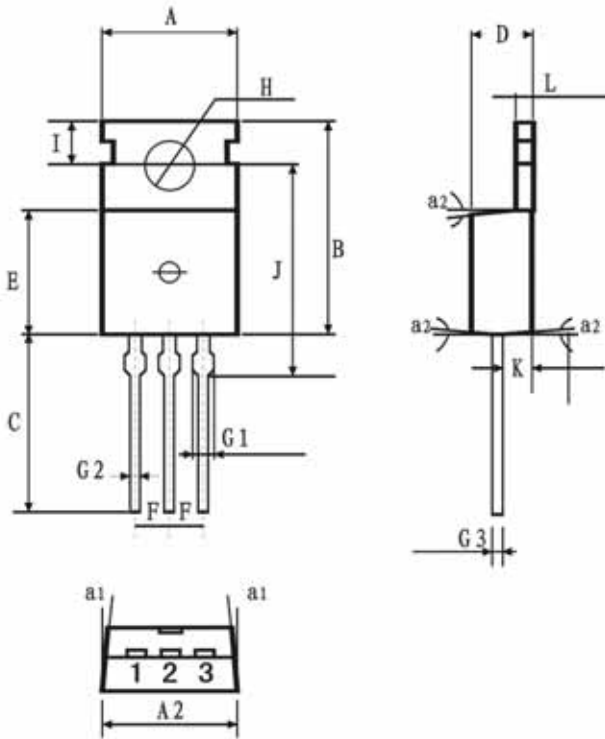

Fig 15. Peak Diode Recovery dv/dt test Circuit & Waveforms

Package Dimensions TO-220



A(mm)	9.66~10.28
A2(mm)	9.80~10.20
B(mm)	15.6~15.8
C(mm)	12.70~14.27
D(mm)	4.30~4.70
E(mm)	8.59~9.40
F(mm)	typical 2.54
G1(mm)	1.32~1.72
G2(mm)	0.70~0.95
G3(mm)	0.4~0.60
H(mm) dia.	3.50~3.83
I(mm)	2.7~2.9
J(mm)	15.70~16.25
K(mm)	2.20~2.90
L(mm)	1.15~1.40
a(degree)	45 °
a2(degree)	3 ° ± 0.5 °
a3(degree)	3 ° ± 0

HISTORY

Issue No	Changed Characteristics	Date	Issuer
V 1.01	Origination	2006.9.14	
V1.31	Package Dimensions	2007.6.05	